



Technical Bulletin 201404

www.jcmglobal.com

For the latest updates on JCM Global products, services, and events, follow JCM Global on FaceBook®, Google®, LinkedIn®, Twitter™, and YouTube™



facebook.com/JCMglobal twitter.com/jcmglobal
 Gplus.to/JCMglobal youtube.com/jcmglobal
 linkedin.com/company/jcm-global

Parts are Parts

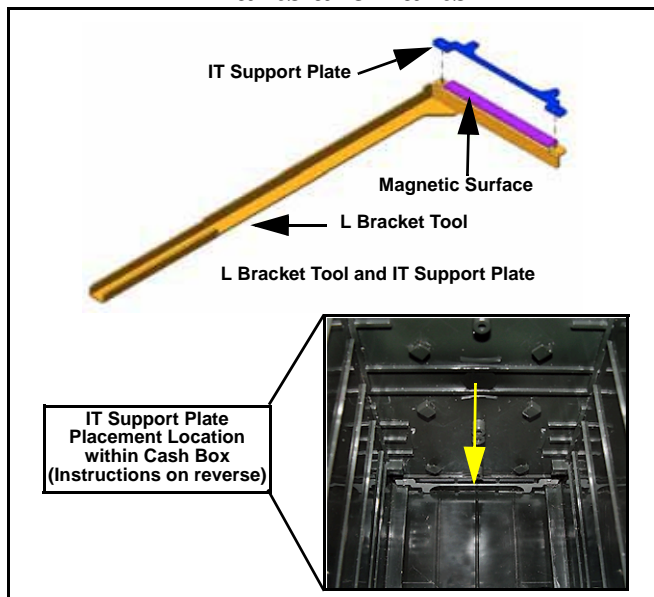

Figure 1: Place IT Support Plate on L Bracket Tool Magnetic Surface

Part No. EDP# 208887

Description: Tool, ICB® Install L-Bracket

Usage: The L Bracket Tool is used to assist in the installation of the IT Support Plate (P/N 200-200473R) in the UBA Standard Cash Box. The L Bracket Tool features a magnetic end that holds the IT Support Plate while it is being placed into position inside the Cash Box. Refer to the Technical Tip on the reverse side of this bulletin for details.

Latest JCM Software Listing

UNIT	Country	ID	Version	Check Sum	CRC
UBA-10/11-SS	USA	ID-003	V-2.51-49	DB4C	1C04
UBA-10/11-SS	USA	ID-024	V-2.51-23	04E9	A0A3
UBA-14/24-SS/SU	USA	ID-003	V-2.51-36		BE96
UBA-14/24-SS/SU	USA	ID-0G8	V-2.51-72		EAEF
UBA-14/24-SS/SU	USA	ID-024	V-2.51-34		39B7
UBA-14/24-SS/SU	USA	ID-028	V-2.51-24		6B9D
iVIZION-100 SS/SU	USA	ID-003	V-2.07-29		C65A
iVIZION-100 SS/SU	USA	ID-024	V-2.07-14		C216
iVIZION-100 SS/SU	USA	ID-028	V-2.11-28		25F4
iVIZION-100 SS/SU	USA	ID-0G8	V-2.14-25		3666
UBA-10/11-SS	CAN	ID-003	V-2.53-50	A351	7FC8
UBA-10/11-SS	CAN	ID-024	V-2.53-23	714C	1455
UBA-14/24-SS/SU	CAN	ID-003	V-2.52-37	959B	B001
UBA-14/24-SS/SU	CAN	ID-024	V-2.52-34		3F71
UBA-14/24-SS/SU	CAN	ID-028	V-2.52-24		B094
UBA-14/24-SS/SU	CAN	ID-0G8	V-2.52-72		AEA1
iVIZION-100 SS/SU	CAN	ID-003	V-2.06-29		FBBC
iVIZION-100 SS/SU	CAN	ID-024	V-2.05-14		51A7
iVIZION-100 SS/SU	CAN	ID-028	V-2.05-27		04BA
iVIZION-100 SS/SU	CAN	ID-0G8	V-2.11-25		05B1

The Latest JCM Software Listing (shown above) identifies specific software versions that have been released to OEMs. It is the responsibility of the OEM to obtain all required approvals from Gaming Regulators and Jurisdictional Authorities necessary for use of approved software versions. Contact the Game Manufacturer (OEM) for information on specific software releases approved for use within your gaming jurisdiction.

JCM recommends using the latest version for maximum acceptance, security, and performance.

JCM Service Offerings

JCM® offers the following services to help keep your JCM Products performing within factory specifications:

Preventive Maintenance Programs	Unit Exchange Programs
Custom Training Classes	ICB® Data Analysis
Warranty and Non-Warranty Service and Repair	Validator Performance Analysis

For additional information, contact your local JCM Sales Representative at (800) 683-7248.

Improve Efficiency, Get Information Quickly with JCM's Sentry® 2 Bezel

The new Sentry 2 Bezel uses the latest technology to display Customer prompts and custom graphics. The Sentry 2 supports multiple languages for Customer prompts, as well as a separate language available for Attendants and Technicians. Settle disputes quickly with a single click of the Key FOB. When clicked, the last 5 Banknotes of TITO Tickets inserted will be displayed, along with their direction of insertion. Attendants can quickly determine the status of the Cash Box, Validator Acceptance Rate and Software information, all without opening a Game Door.





FREE REGIONAL TRAINING

Give your technicians the tools they need to keep your customers happy and your equipment running at peak efficiency.

For the local and regional training schedule, visit:

<http://www.jcmglobal.com>

Technical Bulletin 201404 April 2014

Technical Tips

Question: How is the ICB Module Support Plate easily installed in the UBA Standard Cash Box?

Answer: As shown in Parts is Parts (see reverse), the L Bracket Tool is used to insert and hold the IT Support Bracket in place while the ICB Module is being installed. To install it:

1. Place the IT Support Bracket on the L Bracket Tool's magnetic surface (see **Figure 1**).
2. Slide the L Bracket Tool down the side of the UBA Cash Box (**Figure 2**).
3. Set the IT Support Bracket into position.
4. While holding the Support Bracket in position, set the ICB Module housing in position, and then secure the ICB Module housing to the Support Bracket with two screws (**Figure 3**).

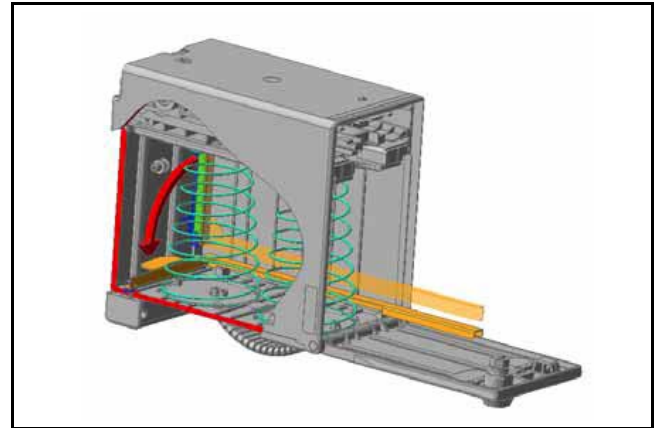

Figure 2 - Installing the L Bracket Tool into the UBA Cash Box

For more information, contact your local JCM Sales Representative at (800) 683-7248.

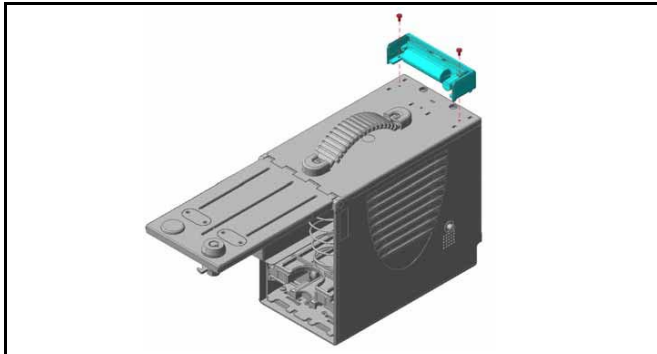

Figure 3: Securing the ICB Module Housing in the Support Bracket

Current Service Manual Releases

Product	Rev.	Product	Rev.
BlueWave DX (German)	A	iVIZION	4
DBV-30X	4	Taiko (PUB-7/11)	4
DBV-500 Integration Guide	A	TBV	1
DT-200 BlueWave 2	5	TBV-101-ASH	A
EBA-3X	4	UBA 10/11/14/24/25	3b
ICB Service Manual	4	UBA-RC	1
ICB Web Reports Ops Manual	1	VEGA	2
iPRO	A	VEGA-RC	2
iPRO-RC	1	PayCheck 4 Owner's Manual	A
RC-10 Service Manual	1	PayCheck 4 Technician's Manual	A
JCM Tool Suite	2		

To access Current Service Manuals, point your web browser to: <http://www.jcmglobal.com/en/support/downloads/manuals.aspx>



JCM TECHNICAL SUPPORT CONTACTS

Headquarters (Japan)

Sales and Service +81-3-5962-3731 hq-jp@jcmglobal.com

Europe, Africa, Russia, Middle East

Sales +49-211-530645-50
Service +49-211-530645-60 hq-eu@jcmglobal.com

Australia, Oceania

Sales and Service +853 28 72 2684 asiapactechsupport@jcmglobal.com

Southeast Asia

Sales and Service +853 28 72 2684 asiapactechsupport@jcmglobal.com

North/South America/Canada/Caribbean

Toll Free Product Support (800) 683-7248 or (702) 651-0000 techsupport@jcmglobal.com

After Hours Americas Support

JCM American prides itself in offering the best Customer Service in the industry. We offer a 24 hour After Hours Hotline, where Technical Support Personnel can be reached at any time, 7 days a week. To reach our 24/7 After Hours Hotline:
1.) Call JCM American at (800) 683-7248.
2.) Select "Option 1" and wait for the call to be transferred to the JCM after hours Technical Support line.
3.) Speak with a certified JCM Support Technician about your situation.

JCM is a registered trademark of JCM American Corporation. All other product names mentioned herein may be registered trademarks or trademarks of their respective companies. Furthermore, TM and © are not mentioned in each case in this publication.